

MONTAGGIO DA EFFETTUARE IN ALMENO DUE PERSONE
 ASSEMBLY TO BE CARRIED OUT BY AT LEAST TWO PEOPLE
 MONTAGE À EFFECTUER PAR AU MOINS DEUX PERSONNES

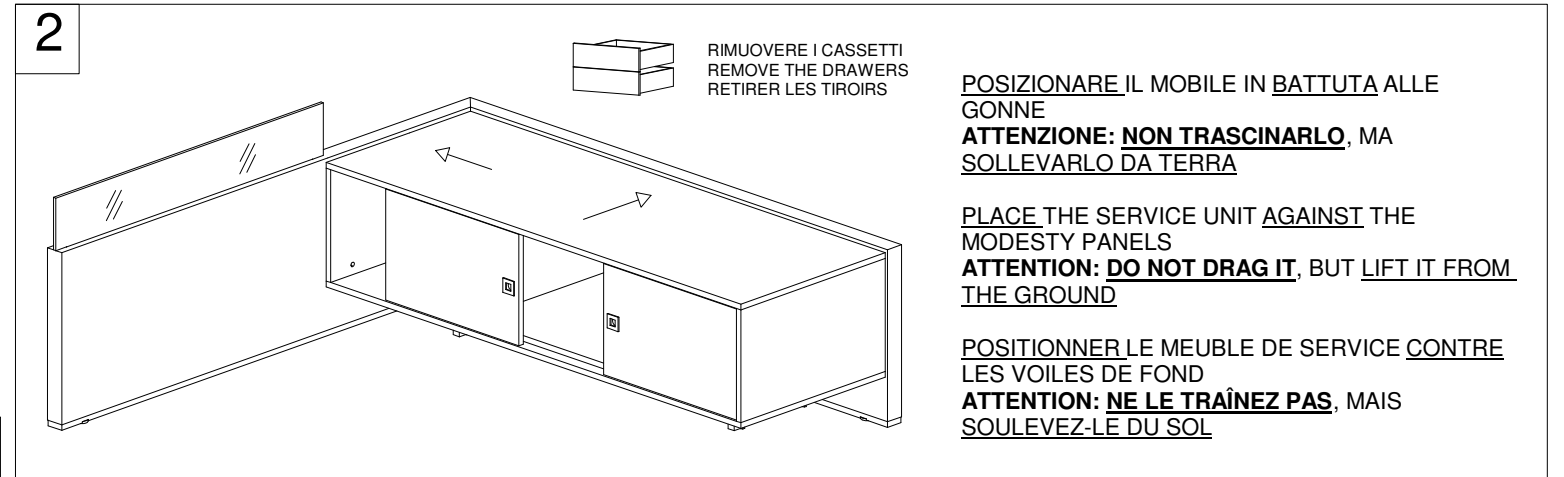
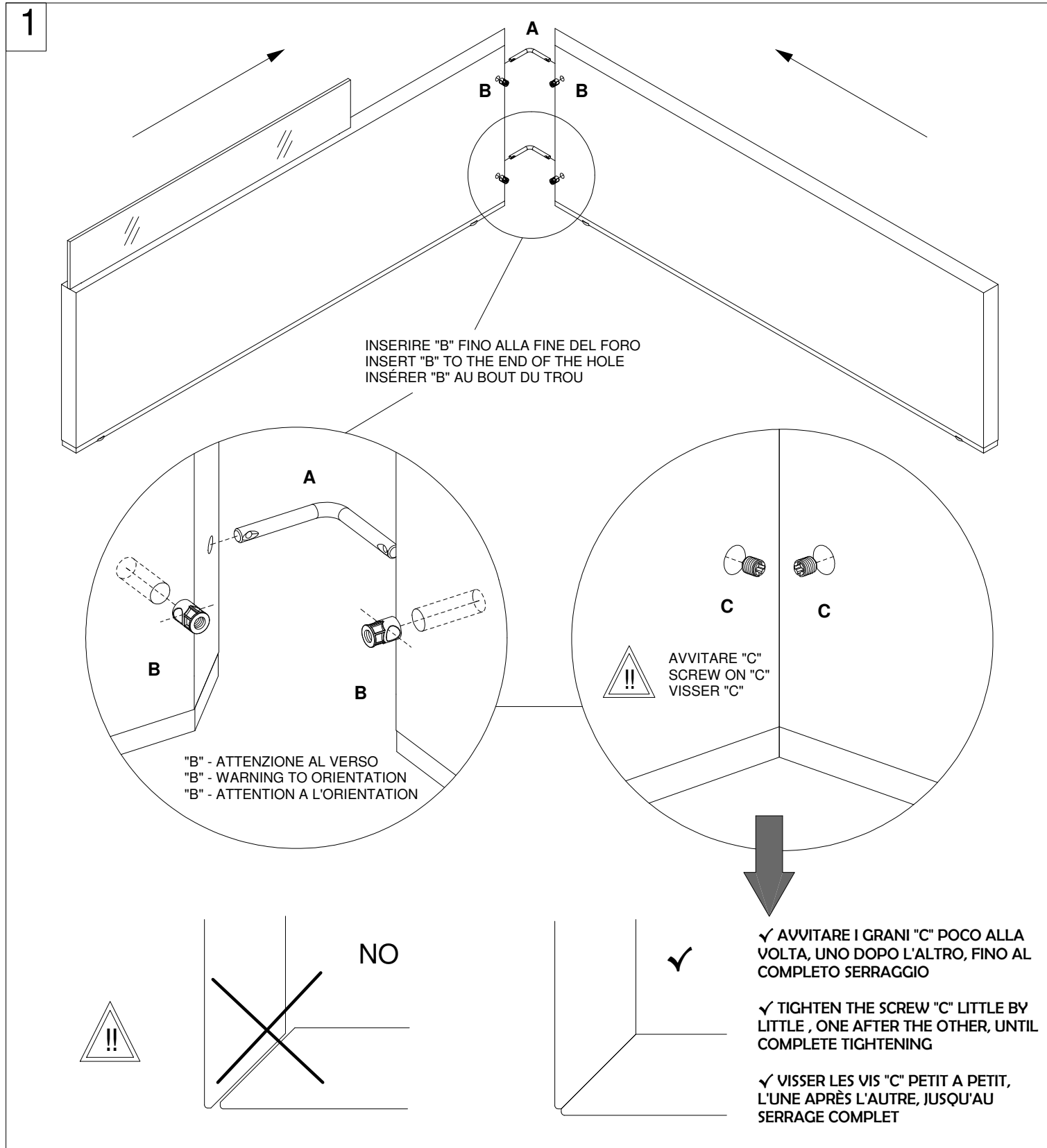

LIVELLARE GONNE E MOBILE DI SERVIZIO - REGOLARE ALTEZZA TRAMITE PIEDINI REGOLATORI
 DIFFERENZA ALTEZZA TRA GONNE E MOBILE: **12mm** (come in figura)
 UTILIZZARE IL VETRO LATERALE PER VERIFICARE IL CORRETTO POSIZIONAMENTO

LEVEL MODESTY PANELS AND SERVICE UNIT - ADJUST THE HEIGHT USING THE LEVELLING FEET
 HEIGHT DIFFERENCE BETWEEN MODESTY PANELS AND SERVICE UNIT: **12mm** (as shown)
 USE THE LATERAL GLASS TO VERIFY CORRECT POSITIONING

NIVELER VOILES DE FOND ET MEUBLES DE SERVICE - AJUSTER LA HAUTEUR VIA LES PIEDS REGLABLE
 DIFFÉRENCE HAUTEUR ENTRE VOILES DE FOND ET MEUBLE: **12mm** (comme sur la figure)
 UTILISER LA VITRE LATÉRALE POUR VÉRIFIER LE BON POSITIONNEMENT

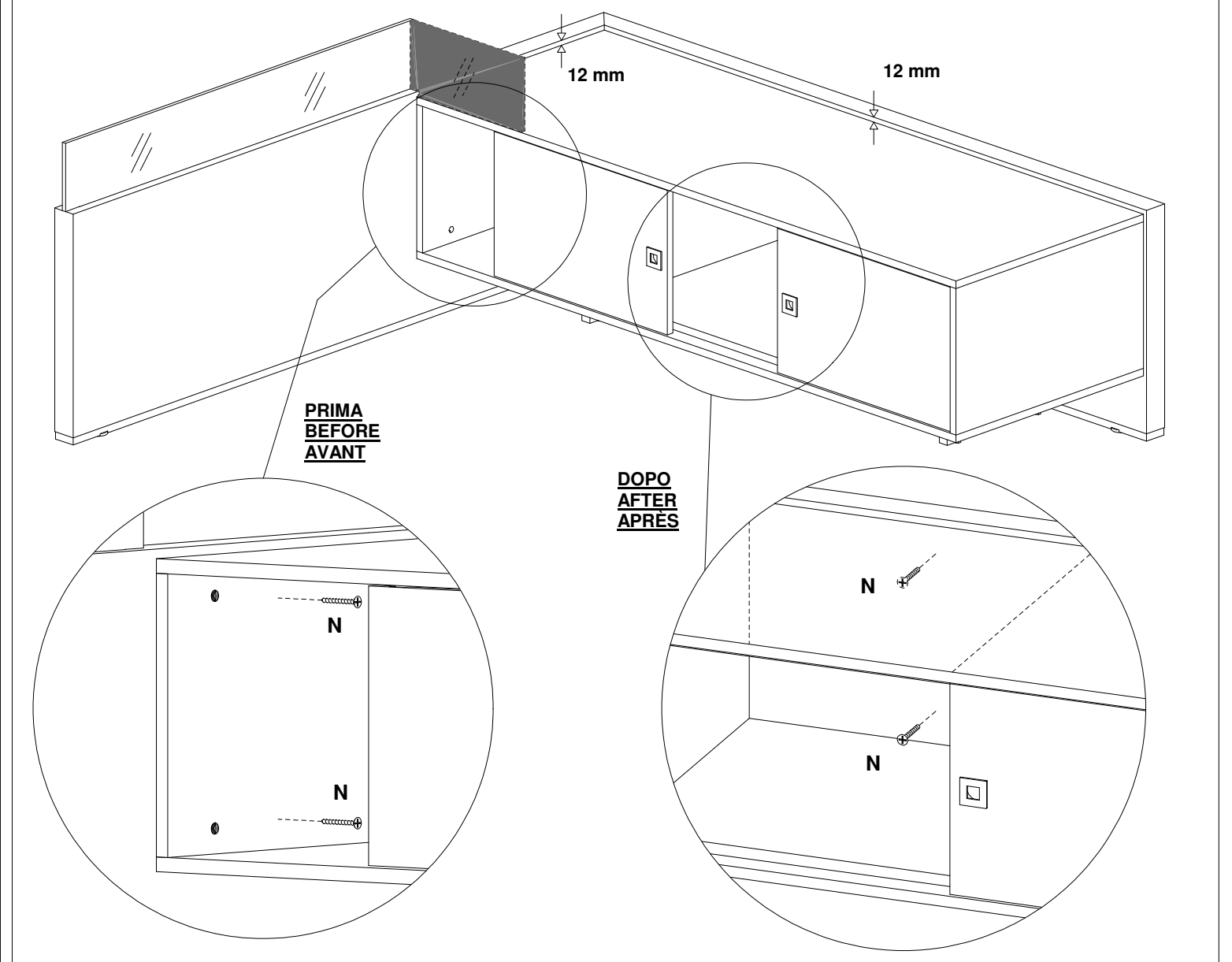

3

"B" - ATTENZIONE AL VERSO - INSERIRE FINO ALLA FINE DEL FORO
 "B" - WARNING TO ORIENTATION - INSERT TO THE END OF THE HOLE
 "B" - ATTENTION A L'ORIENTATION - INSÉRER AU BOUT DU TROU

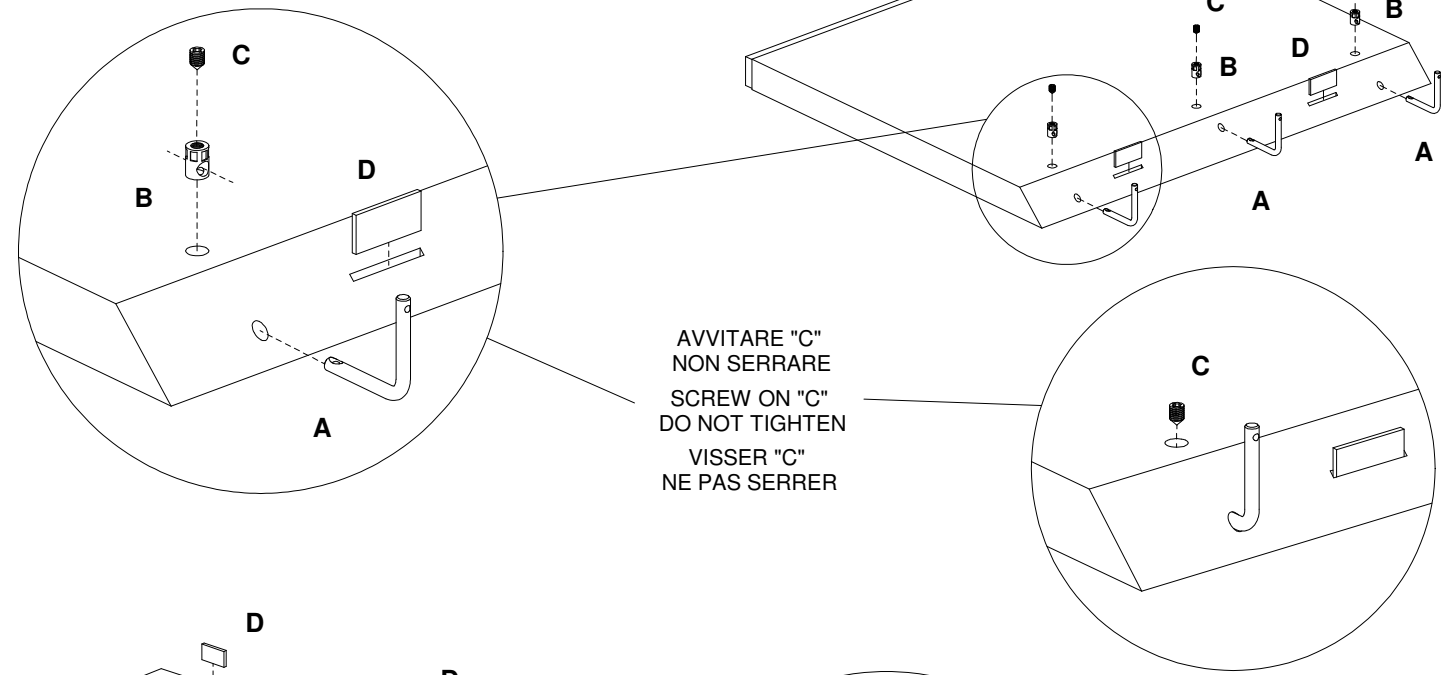

AVVITARE "C"
 NON SERRARE
 SCREW ON "C"
 DO NOT TIGHTEN
 VISSER "C"
 NE PAS SERRER

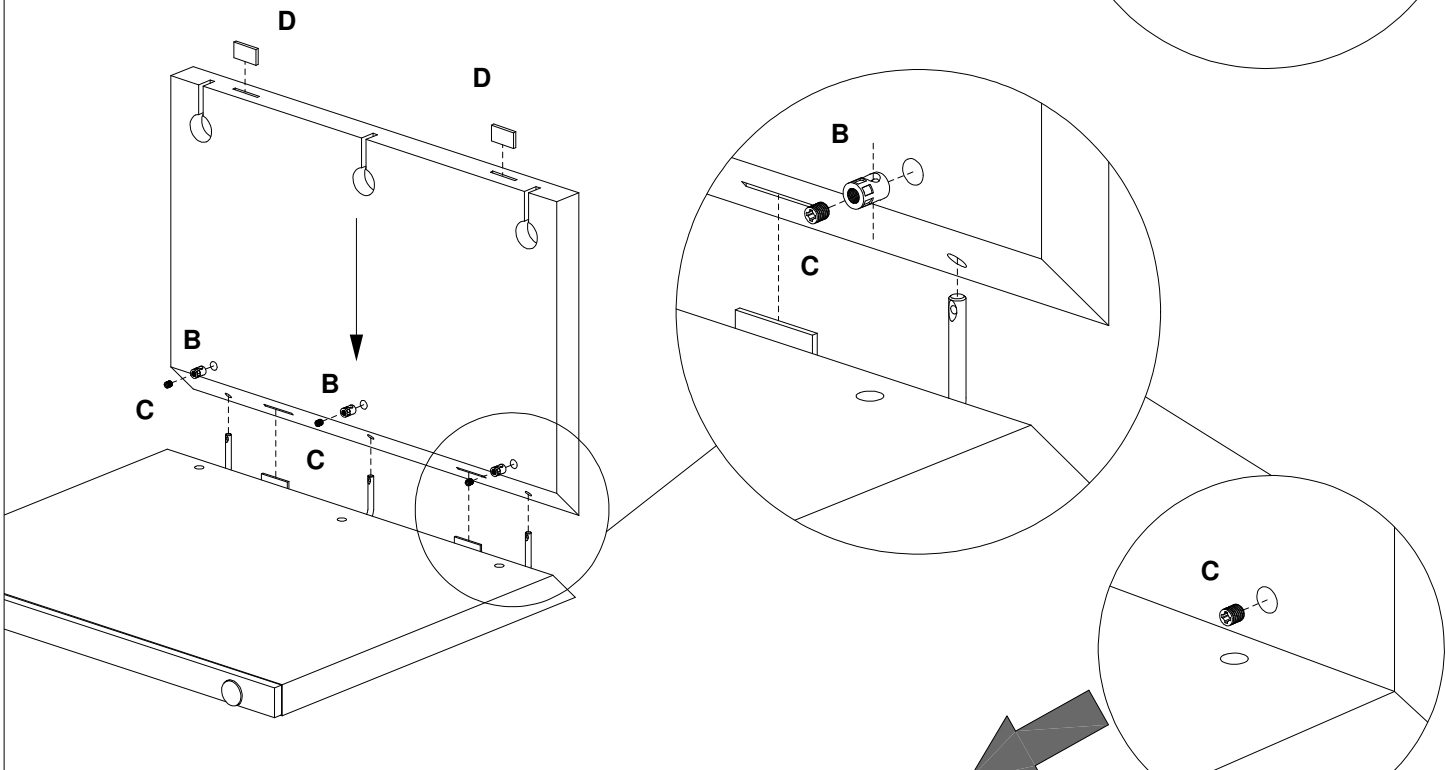

REGOLARE (SE NECESSARIO) IL CORRETTO ALLINEAMENTO TRA PIANO E FIANCO
 COME INDICATO IN FIGURA ✓
 ADJUST (IF NECESSARY) THE CORRECT ALIGNMENT BETWEEN TOP AND SIDE AS
 SHOWN IN THE FIGURE ✓
 RÉGLER (SI NÉCESSAIRE) L'ALIGNEMENT CORRECT ENTRE LE HAUT ET LE CÔTÉ
 COMME INDIQUÉ SUR LA FIGURE ✓

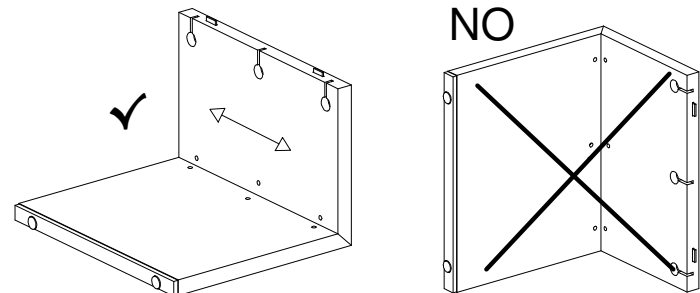

✓ AVVITARE I GRANI "C" POCO ALLA VOLTA,
 UNO DOPO L'ALTRO, FINO AL COMPLETO
 SERRAGGIO
 ✓ TIGHTEN THE SCREW "C" LITTLE BY LITTLE,
 ONE AFTER THE OTHER, UNTIL COMPLETE
 TIGHTENING
 ✓ VISSER LES VIS "C" PETIT A PETIT, L'UNE
 APRÈS L'AUTRE, JUSQU'AU SERRAGE COMPLET

4

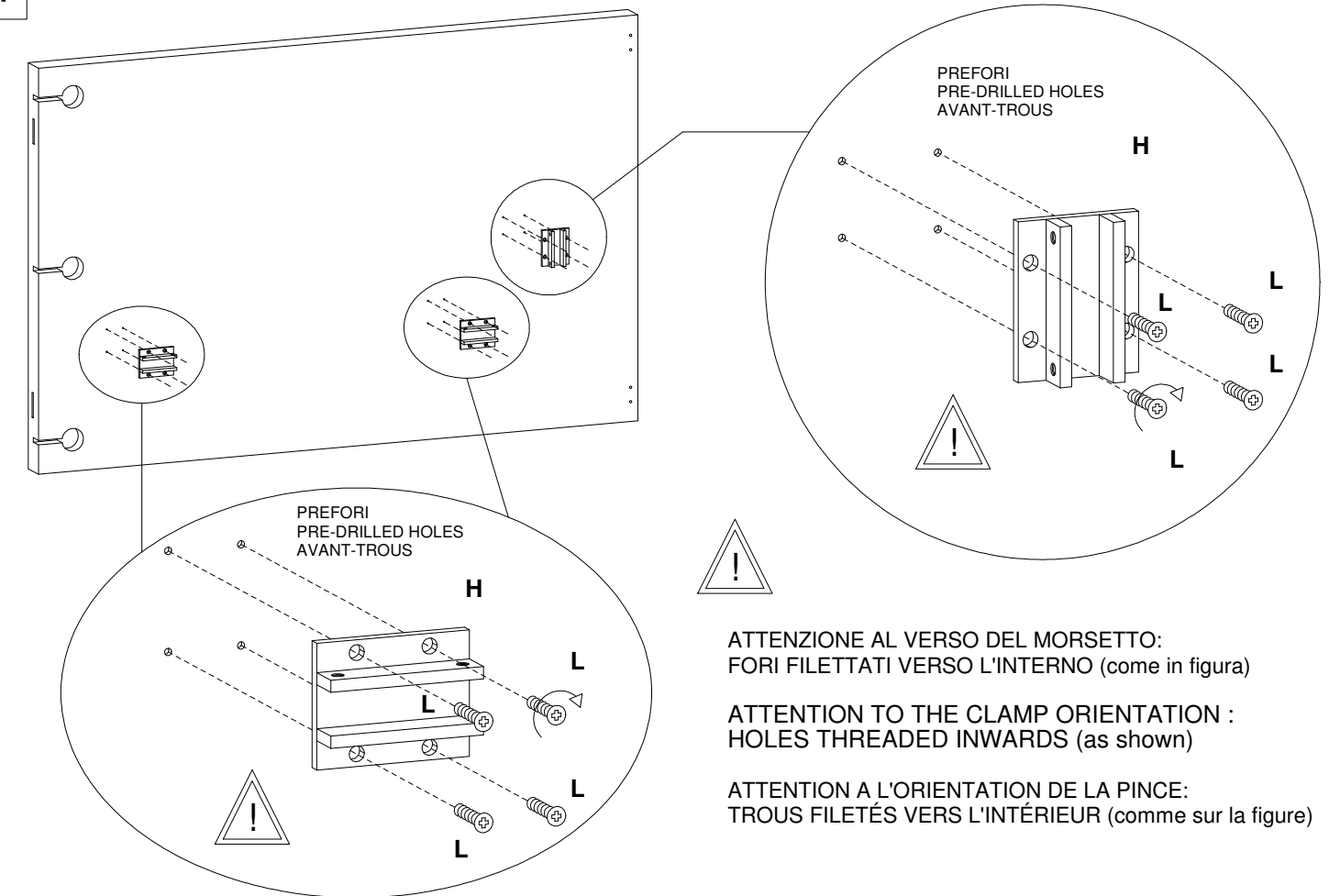

ATTENZIONE AL VERSO DEL MORSETTO:
 FORI FILETTATI VERSO L'INTERNO (come in figura)
 ATTENTION TO THE CLAMP ORIENTATION :
 HOLES THREADED INWARDS (as shown)
 ATTENTION A L'ORIENTATION DE LA PINCE:
 TROUS FILETÉS VERS L'INTÉRIEUR (comme sur la figure)

5

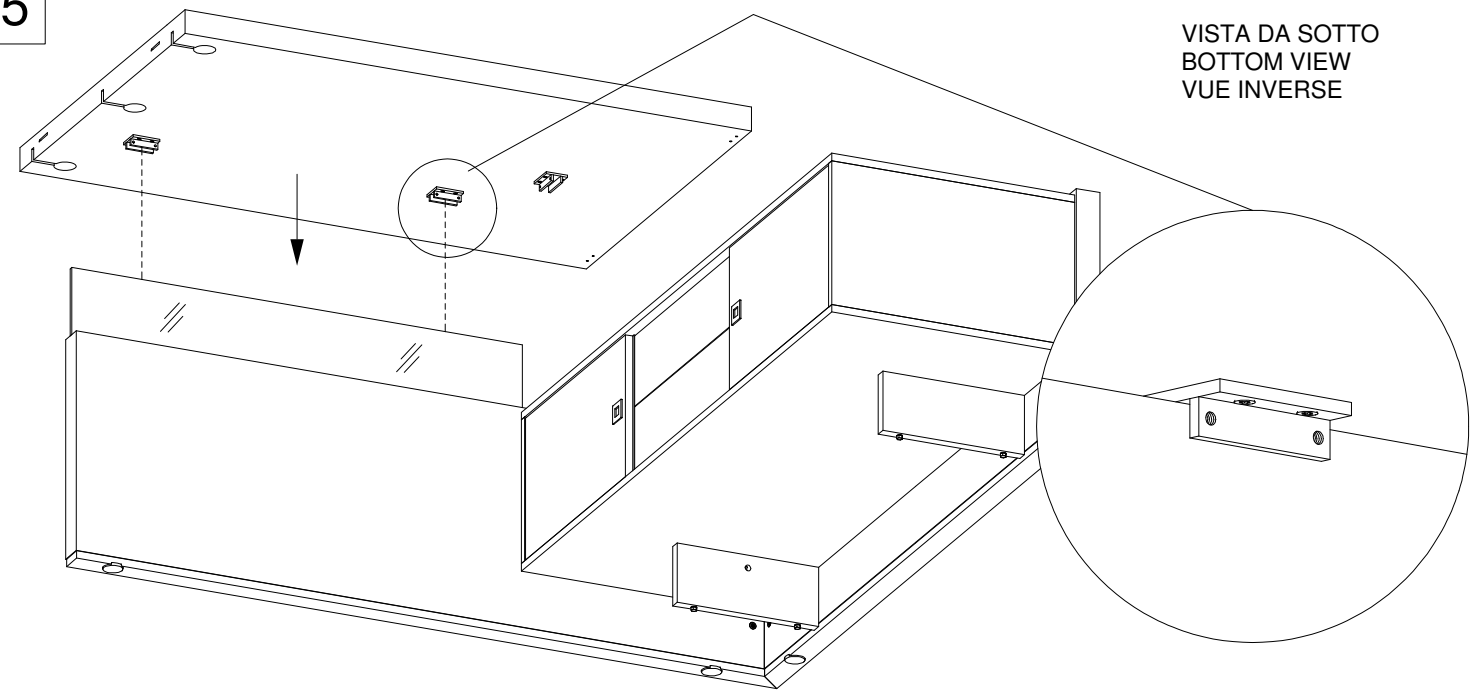

VISTA DA SOTTO
 BOTTOM VIEW
 VUE INVERSE

VISTA FRONTALE
 FRONT VIEW
 VUE DE FACE

POSIZIONE CORRETTA: PIANO A FILO DEL FIANCO
una persona deve sorreggere il piano
 CORRECT POSITION: TOP FLUSH WITH THE SIDE PANEL
one person has to support the top
 POSITION CORRECTE : PLATEAU AU RAS DU CÔTÉ
une personne doit soutenir le plateau

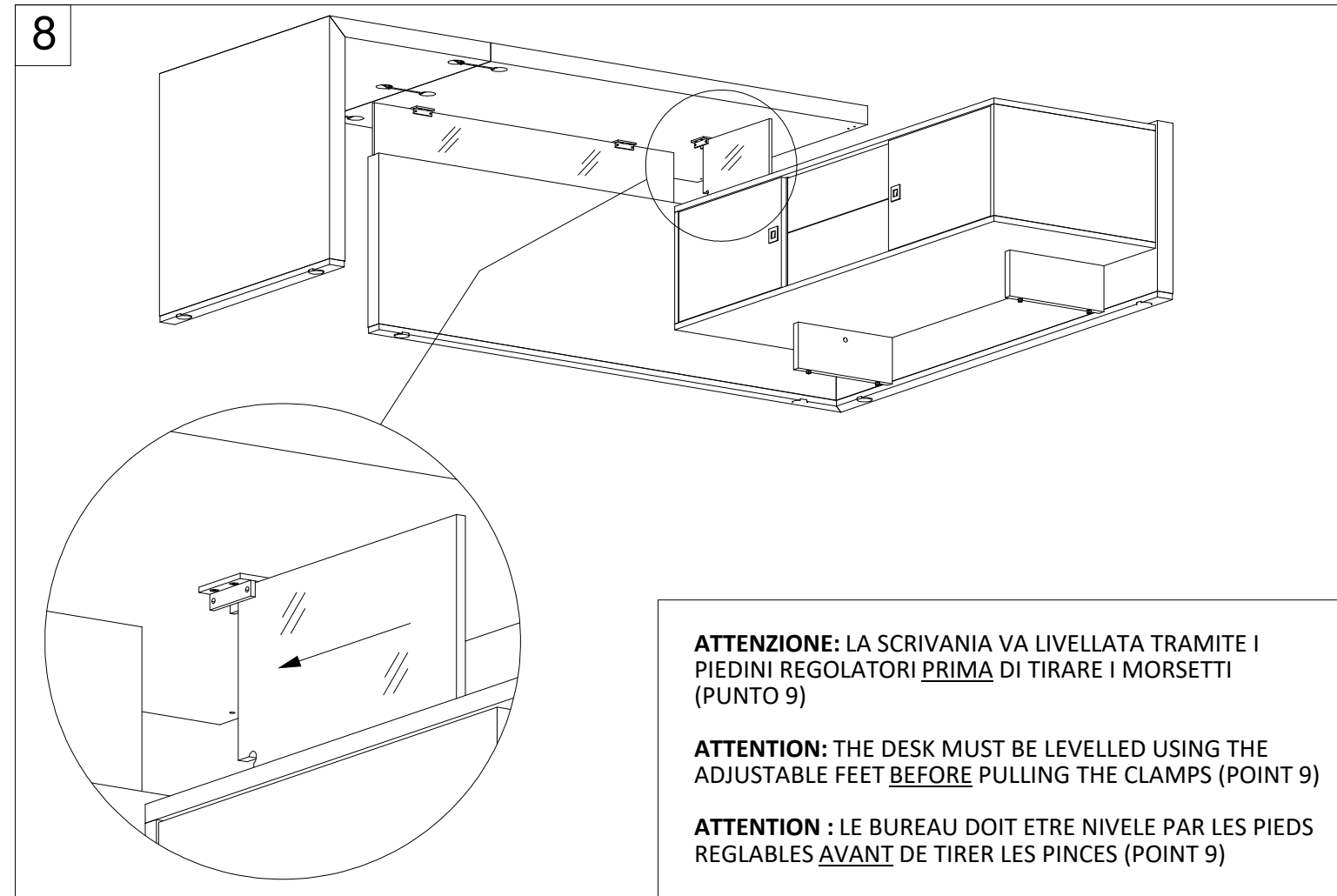
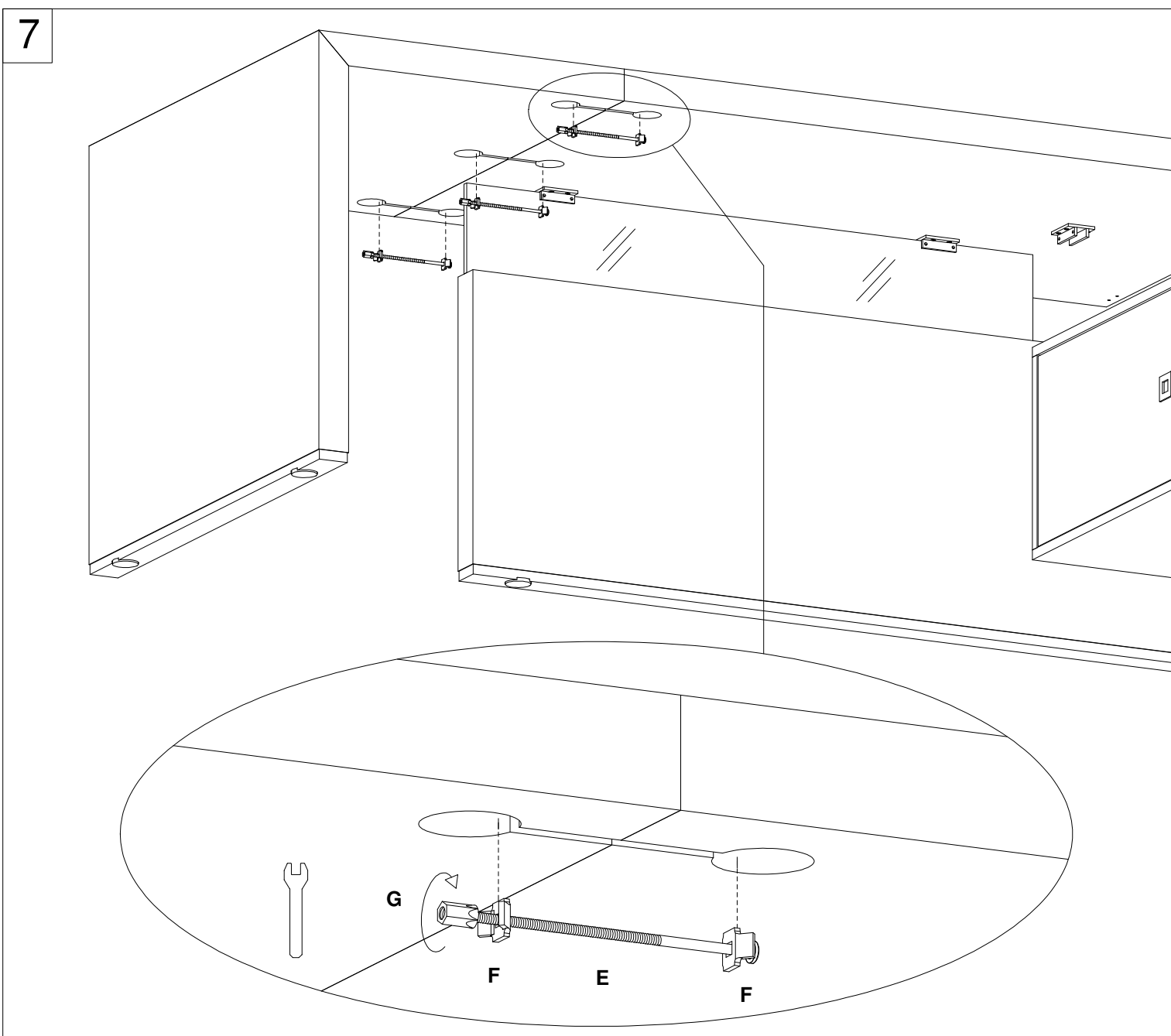
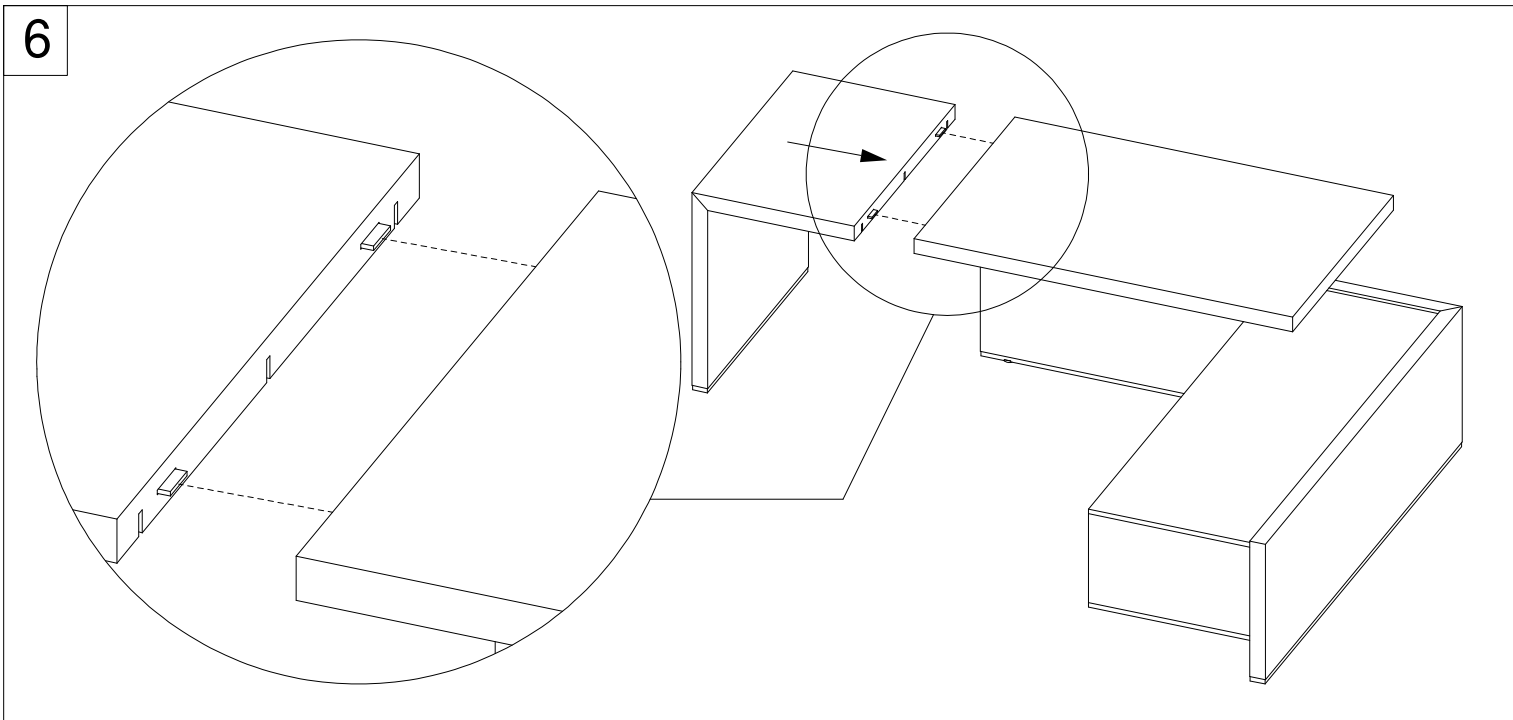

ATTENZIONE: LA SCRIVANIA VA LIVELLATA TRAMITE I PIEDINI REGOLATORI PRIMA DI TIRARE I MORSETTI (PUNTO 9)

ATTENTION: THE DESK MUST BE LEVELLED USING THE ADJUSTABLE FEET BEFORE PULLING THE CLAMPS (POINT 9)

ATTENTION : LE BUREAU DOIT ETRE NIVELE PAR LES PIEDS REGLABLES AVANT DE TIRER LES PINCES (POINT 9)

